

Model: 1654 Specifications

The Vent-A-Kiln model 1654 ventilation system shall include a 54.0" diameter metal spun aluminum hood tapering to a 6.0" diameter exit. A single speed motor with fan (blower) mounted on top the hood, shall draw and propel exhaust fumes and heat via a flexible hose to a exterior surface mounted gravity operated louver. The placement of the hood and blower subassembly shall be user adjustable via an overhead pulley and counterweight system.

- 1) Conical collection hood:
 - 54.0" diameter, 0.063 gage aluminum, alloy 1100-0.
- 2) Non-explosion proof blower
 - 1/2 hp, 1/60/115 motor.
 - 450 cfm @ 0.0" w.g., 3.6 amps, 1600 rpm.
 - Maximum continuous motor Temperature 250 deg. f..
 - Sound data; approximate db at 5 feet: high 88db, low 54db.
- 3) Flexible exhaust hose:
 - Triple ply laminate, aluminized polyester face and an aluminum foil backing.
 - Corrosion, moisture, temperature (250 deg. f.), and flame resistant.
 - 6.0" diameter, 10' (ft.) length.
 - Flexible hose fastened by plastic hose clamps (qty=2).
 - UL listed number 723.
 - Cut to shortest length permissible.
- 4) Exterior surface mounted louver:
 - 6.0" diameter discharge.
 - Blind screen.
 - Three (3) gravity operated shutters.
- 5) 3/8" diameter plastic coated steel cable:
 - 15' (ft.) length.
 - 15' (2) 3/8" galvanized steel cable clamps for fastening cable to counterweight and blower.
- 6) Counterweight:
 - 3.0" diameter cold rolled steel, painted VAF/VAK black.
 - weight = 36.0 lbs..
- 7) Overhead pulley system:
 - 1.0"x1.0"x36.0" length structural tubing.
 - Five (5) ball bearing pulleys.
 - Four (4) slide brackets for hanging of system, alternate left to right.
 - Five (5) pulley safety straps.
- 8) Over all shipping weight:
 - approximately 100lb.

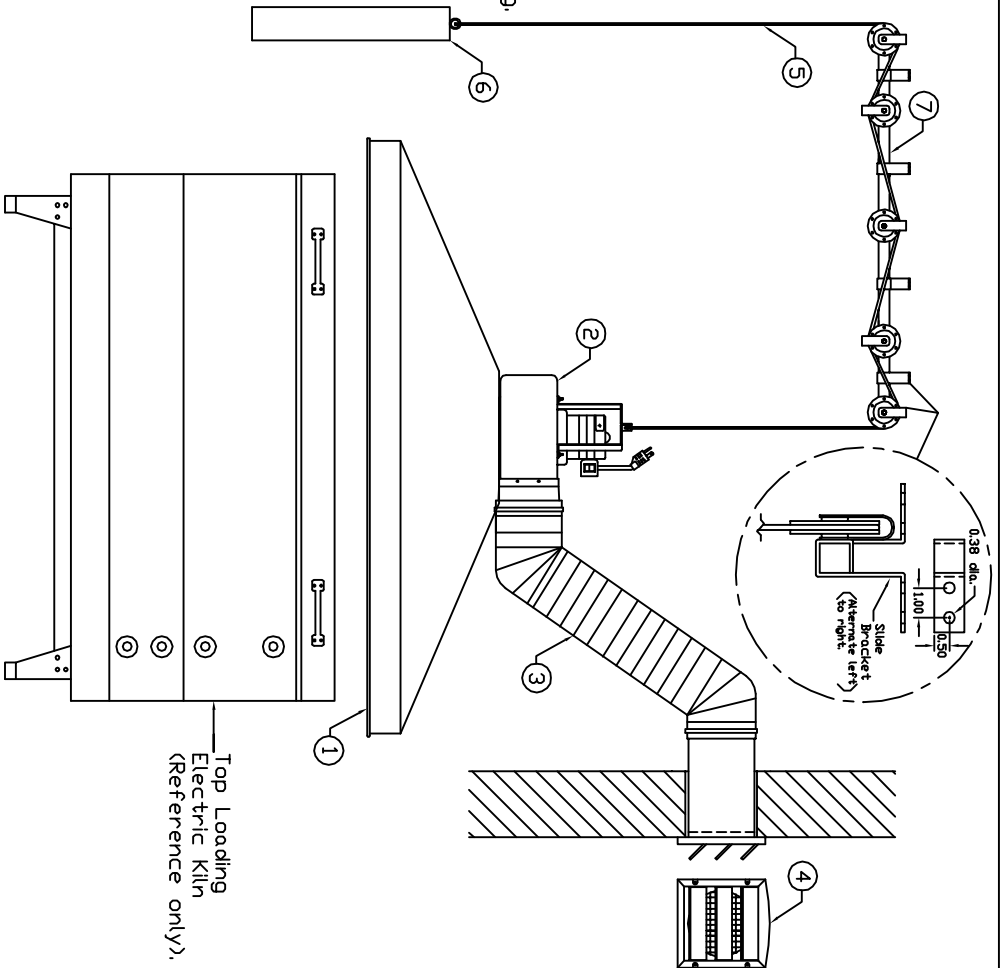

LETTER	ALTERATION	DATE	BY
A	Blower motor had two speeds	6/12/09	B-Brandon

UNLESS SHOWN OTHERWISE TOLERANCES SHOULD BE:
 1) .004
 2) .01
 3) FRACTIONAL DIMENSIONS ± 1/32"
 4) ANGLES ± 0° 30'

ALL INFORMATION CONTAINED HEREIN IS PROPRIETARY AND MUST NOT BE REPRODUCED OR MADE PUBLIC WITH-OUT WRITTEN CONSENT FROM Vent-A-Kiln/Vent-A-Kiln Corp.

Vent-A-Kiln Corp. 51 Botsford Place Buffalo, N.Y. 14216 Positive Pressure		PROJECT XXX DATE 8/4/03 SCALE NTS	DRAWN BY CHECKED BY BILL OF MAT'L
TITLE: Model: 1654 System Layout (P-10 Blower)		DWG. NO. B-1052	REV. A

All Dimensions Inches